

T2000 mobiles

T2004 Multi Control Head
System Manual

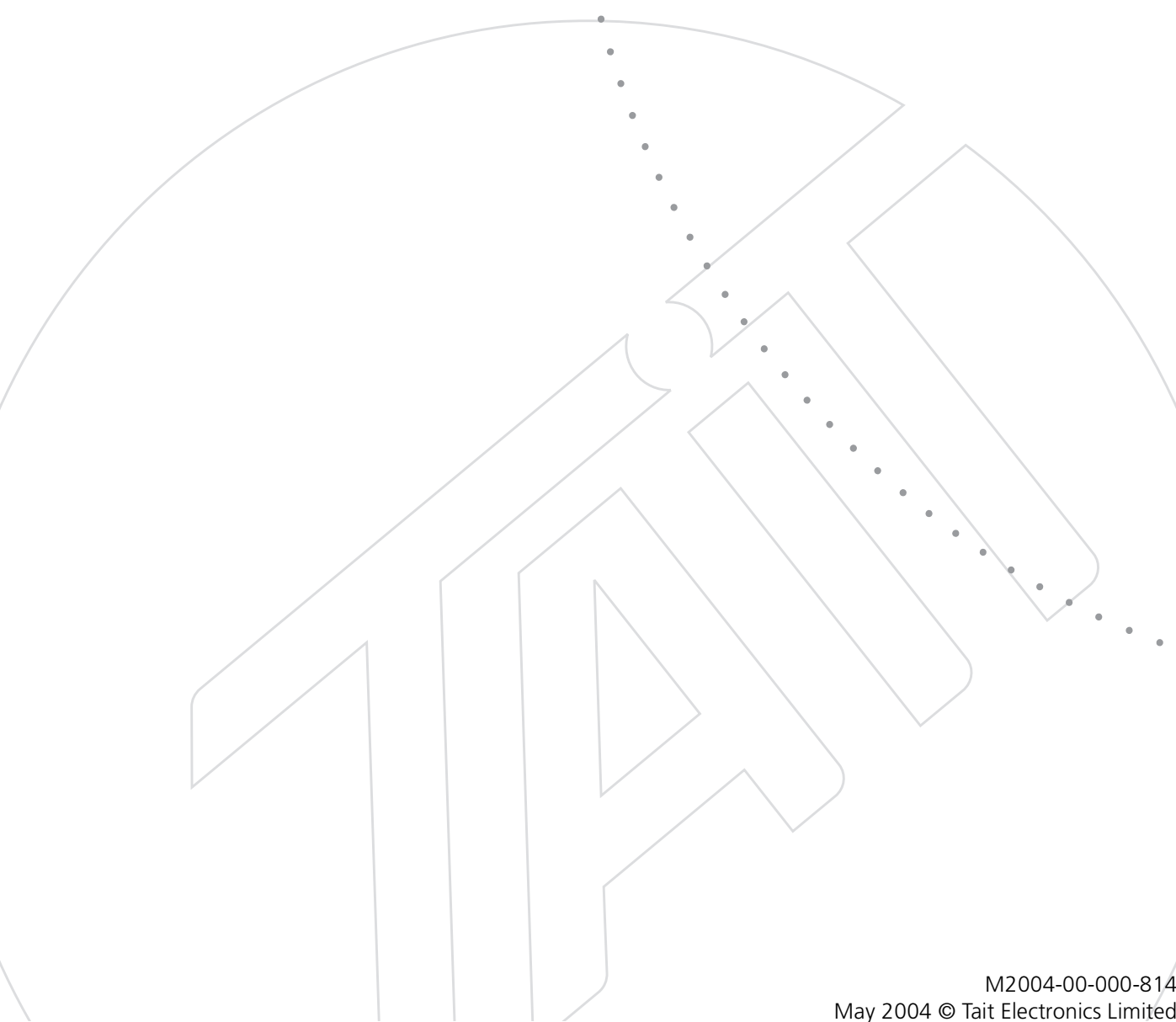

Contact Information

Tait Radio Communications

<http://www.taitworld.com>

Corporate Head Office New Zealand

Tait Electronics Ltd.
P.O. Box 1645
Christchurch
New Zealand

E-mail (Marketing): taitnet@taitworld.com
E-mail (Sales): sales@taitworld.com

Technical Support

Technical Support Manager
Tait Electronics Ltd
P.O. Box 1645
Christchurch
New Zealand

Telephone: (64) (3) 358-3399
Facsimile: (64) (3) 358-6486
E-mail: support@taitworld.com

Oceania

New Zealand
Tait Communications Ltd.
E-mail: headoffice@tcl.tait.co.nz

Australia
Tait Electronics (Aust) Pty Ltd.
E-mail: australia@taitworld.com

Tait Europe

Regional Head Office - United Kingdom
Tait Mobile Radio Ltd.
E-mail: teusales@tait.co.uk

Tait North America

Regional Head Office - Canada
Tait North America Inc.
E-mail: canada@taitworld.com

United States of America
Tait North America Inc.
E-mail: usa@taitworld.com

Latin America

Tait Latin America
E-mail: latinamerica@taitworld.com

Tait North Asia

Regional Head Office - Hong Kong
Tait Mobile Radio (Hong Kong) Ltd.
E-mail: hongkong@taitworld.com

Beijing
Tait Mobile Radio (Hong Kong) Ltd.
E-mail: beijing@taitworld.com

Tait South Asia

Regional Head Office - Singapore
Tait Electronics (Far East) Pte. Ltd.
E-mail: singapore@taitworld.com

Thailand
Tait Mobile Radio Ltd.
E-mail: thailand@taitworld.com

Contents

Contact Information	2
Preface	7
Scope of Manual	7
Copyright	7
Disclaimer	7
Enquiries and Comments	7
Associated Documentation	7
Updates of Manual and Equipment	8
Publication Record	8

Part A System Information

1 Introduction	11
1.1 Document Navigation	11
1.2 Product Codes	12
2 System Overview	13
2.1 System Specifications	14
2.2 System Diagram	15
2.3 System Equipment	16
2.4 System Connections	19
3 System Installation	20
4 System Operation	21
5 System Equipment Specifications	22
5.1 Multi-Drop Cable Specifications	22
5.2 Micromatch to RJ45 Cable (IPN 219-02900-00)	23
5.3 RJ45 Wallbox	24
5.4 DC Power and Speaker connections	25
6 System Testing	27
5 System Fault Finding	28

Part B T2004 Control Heads

1	Introduction	33
1.1	The T2004 Control Heads	33
1.2	Features	33
1.3	Product Codes	35
2	Circuit Description	36
3	Functionality	38
3.1	Software	38
4	I/O Connections	40
4.1	J6: Power and Speaker Connector	40
4.2	J5: 8way Micromatch Socket	41
4.3	S10: 6way RJ Socket (Microphone)	41
5	Assembly/Disassembly Instructions	42
5.1	Mechanical Parts	42
5.2	Disassembling the Control Head	43
6	X2H2xx PCB Information	45
6.1	X2H221 Rev 007 Parts List.	47
6.2	X2H221 Rev 007 Grid Reference.	49
6.3	228-23722-02 PCB Top Side	52
6.4	228-23722-02 PCB Bottom Side.	53
6.5	X2H221- PCB Circuit Diagram (page 1 of 1)	55
7	Testing the X2H2xx control heads	57

Part C X2AM01 Radio Interface

1	Introduction	60
1.1	The X2AM01 Multi-Head Radio Interface PCB	60
2	Circuit Description	61

3	I/O Connections	62
3.1	SK1: 8 Way Micromatch Socket to Radio	62
3.2	SK3: 8 Way Micromatch Socket to Control Heads	62
4	Fitting PCB into Radio	63
5	X2AM01 Multi-Head Radio Interface PCB	65
5.1	X2AM01 Rev 008 Parts List	65
5.2	X2AM01 Rev 008 Grid Reference	69
5.3	228-23721-01 PCB Top Side.	70
5.4	228-23721-01 PCB Bottom Side	71
5.5	X2MA01 PCB Circuit Diagram (page 1 of 1).	72
6	Testing the X2AM01 radio interface	73

Preface

Scope of Manual

This manual contains general and technical information about the T2004 Multi-Control Head system for use with a T2000 radio.

Copyright

All information contained in this manual is the property of Tait Electronics Ltd. All rights are reserved. This manual may not, in whole or in part, be copied, photocopied, reproduced, translated, stored, or reduced to any electronic medium or machine-readable form, without prior written permission from Tait Electronics Limited. All trade names referenced are the service mark, trademark or registered trademark of the respective manufacturers.

Disclaimer

There are no warranties extended or granted by this manual. Tait Electronics Ltd accepts no responsibility for damage arising from use of the information contained in the manual or of the equipment and software it describes. It is the responsibility of the user to ensure that use of such information, equipment and software complies with the laws, rules and regulations of the applicable jurisdictions.

Enquiries and Comments

If you have any enquiries regarding this manual, or any comments, suggestions and notifications of errors, please contact Customer Support, Tait Electronics Ltd, Christchurch, New Zealand (refer to “Contact Information” on page 2).

Associated Documentation

T2004 Multi-Control Head Installation Manual M2004-00-000-315

Updates of Manual and Equipment

In the interests of improving the performance, reliability or servicing of the equipment, Tait Electronics Ltd reserves the right to update the equipment or this manual or both without prior notice.

Publication Record

Issue	Publication Date	Description
0	April 2004	new manual

Part A System Information

This part provides general information about the T2004 Multi Control Head and describes how to install and operate the system.

The following topics are covered in this part:

- Section 1 Introduction
- Section 2 System Overview
- Section 3 System Installation
- Section 4 System Operation
- Section 5 System Equipment Specifications
- Section 6 System Testing
- Section 7 System Fault Finding

1 Introduction

1.1 Document Navigation

System Manual

This System Manual is divided into three parts.

- Part A provides general information about the system, how the components are connected together, system installation and operation instructions, and specifications for equipment in the system, excluding the control heads and radio.
- Part B provides technical information about the control heads, including a circuit description, PCB layout and circuit diagram, and testing information.
- Part C provides technical information about the Radio Interface PCB, including a circuit description, PCB layout and circuit diagram, and testing information.

Control Head/Radio User Guide

Installation and operation instructions included in Part A of the System Manual provide instructions unique to this system. For more detailed operation instructions, refer to the user guide.

Radio Service Manual

The System Manual does not contain information about the T2020 or T2040 radio used with the system. For information about the radio, refer to the T2000 Series II Service Manual (M2000-00-301).

1.2 Product Codes

The T2004 Multi-Control Head system replaces the STA6682 Multi Control Head system, previously manufactured by Tait Communications Ltd. (TCL).



Note The T2004 is not compatible with existing STA6682 heads or interface boards.

The table below provides the product numbers for both systems.

Product Code	Description	TCL Code
T2004-A20	T2020 Primary Multi-Control Head Kit	
T2004-A21	T2020 Secondary Multi-Control Head Kit	
T2004-A40	T2040 Primary Multi-Control Head Kit	
T2004-A41	T2040 Secondary Multi-Control Head Kit	
X2H221	T2020 Primary Control Head only	STA6682-4H
X2H222	T2020 Secondary Control Head only	STA6682-4H
X2H241	T2040 Primary Control Head only	STA6682-4H
X2H242	T2040 Secondary Control Head only	STA6682-4H
X2AM01	T2020/40 Multi-Control Head Radio Interface PCB	STA6682-1H

2 System Overview

The T2004 Multi-Control Head system allows the use of between one and five control heads with a single T2020 or T2040 radio. The control heads are configured as one Primary and up to four Secondary. The Primary control head is the only one which controls the radio's power, as well as power to each Secondary control head, otherwise the functionality of all the control heads is the same. Advantages: radio to control head length able to be greater than the standard 6m cable.



The Multi-Control Head system consists of two kits, designed to connect to your existing Series II T2020 or T2040 radio and T2008 power supply:

- the T2004-A20 (T2020) or the T2004-A40 (T2040) Primary Multi-Control Head Kit (one required per system).
- the T2004-A21 (T2020) or T2004-A41 (T2040) Secondary Multi-Control Head Kit (not required if only one control head is used in the system).

The T2004-A20 or T2004-A40 Primary Head Kit provides the Primary control head as well as the Radio Interface PCB. This PCB is housed inside a dummy (Clayton's) control head and replaces the standard control head on the radio. The radio can be concealed if required, as all radio controls are now done via the Primary control head.

The T2004-A21 or T2004-A41 Secondary Head Kit provides one Secondary control head and other equipment needed to install the control head for use with the radio.

Each control head can be installed anywhere on a multi-drop line up to 2000m long (not included), and is powered locally by a mains-operated DC plug pack. A speaker plugs into each control head to provide local Tx and Rx audio.

Note The DC Plug pack is not supplied as part of the kit. The correct plug pack for each country can be ordered separately as per the table on page 18.

The control heads provide the same functionality as the standard T2000 control head, but will not provide for a DTMF module to be fitted. In addition, the control heads provide some extra functions:

■ **Global Mute**

The Global Mute function is provided to avoid the possibility of audio feedback when two or more control heads are placed in close proximity. This function is individually selectable on each control head, via a link JP1 on the control head PCB. Refer to Part B, Control Head for further information.

■ **Power Switch Selection**

The Power Switch Selection function is provided so that only one control head in the system (the Primary control head) is able to control the system's power. This function is selectable by the fitting of a jumper (JP2) on the control head PCB of the Primary control head. Refer to Part B, Control Head for further information.

2.1 System Specifications

General Specifications

Radios supported	Series II T2020 and T2040 radios
Possible number of control heads	Between one and five
Control head DC supply & speaker connector	Phoenix MCV 1,5/4-G-3,81 4 way jack
Control head DC supply voltage (at 800mA)	+13.8V nominal +10.8V minimum +16.0V maximum
Balanced line Audio levels	-10dBm for receiver audio -15dBm for transmitter audio
Control head dimensions	Standard T2000 control head dimensions
Recommended cable	4 x twisted pair with overall screen

2.2 System Diagram

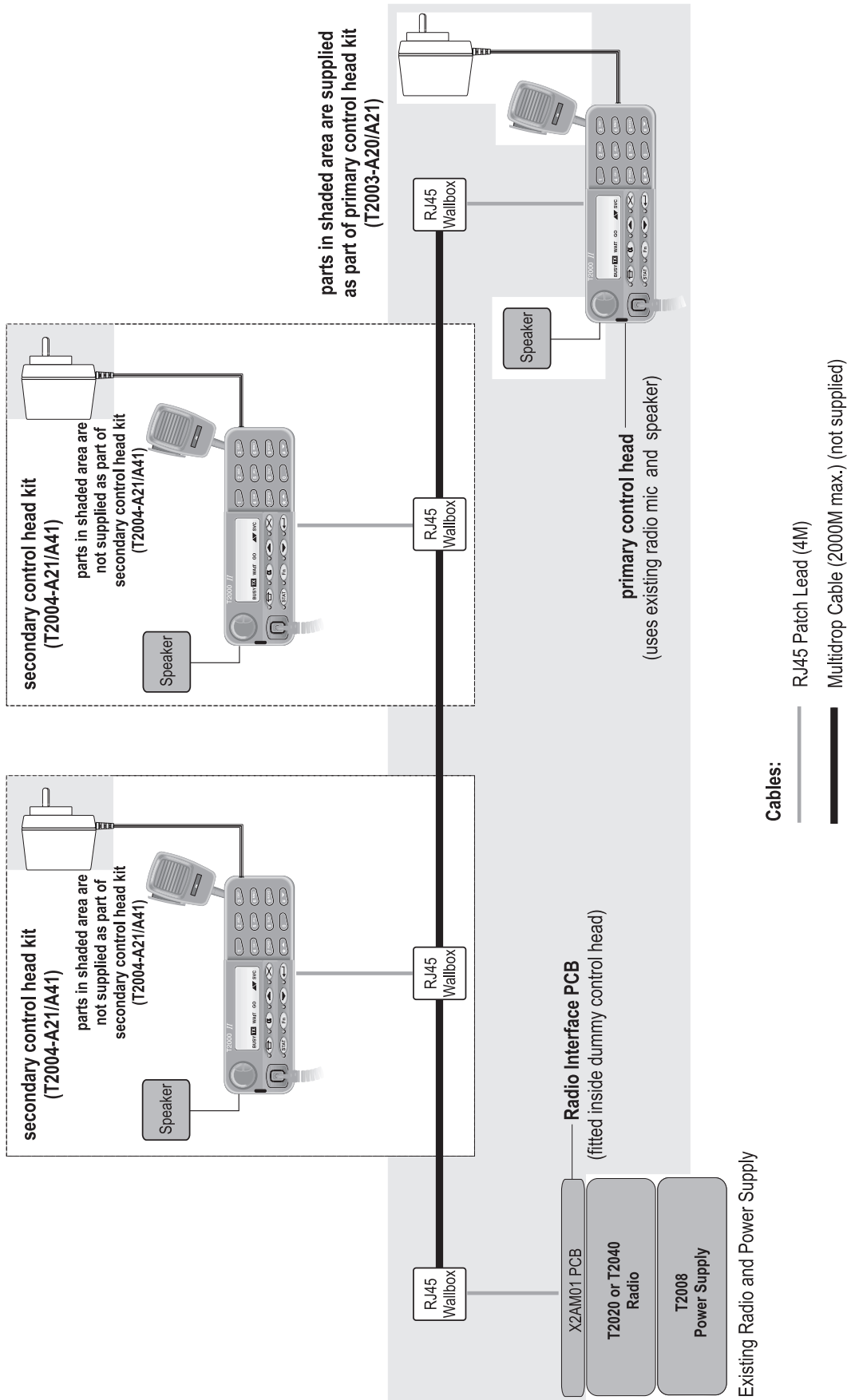

2.3 System Equipment

The Multi-Control Head system includes the following components:

- one T2020 or T2040 radio with T2008 power supply unit (existing)
- 2km maximum Multidrop Line (not supplied)
- one T2004-A20 or T2004-A40 Primary Multi-Control Head Kit
- between one and four T2004-A21 or T2004-A41 Secondary Multi-Control Head Kit (optional)

T2004-A20 and T2004-A40 Primary Multi-Control Head Kit Parts

The T2004-A20 or T2004-A40 Primary Multi-Control Head Kit are listed below:

Qty	IPN	Description
1	X2H221 or X2H241	T2020 or T2040 Primary Control Head ^a
1	X2AM01	T2020/40 Multi-Control Head Radio Interface ^b
2	219-02900-00	Micromatch to RJ45 cable
2	240-04051-00	RJ45 Screw Terminal Wallbox
2	349-00010-33	Screw, #6*3/4: S/T P/P (bracket to wall)
4	349-00010-22	Screw, 4-20x3/8 P/P Trilb-P BZ (dummy head to radio)
1	316-06433-02	Dummy (Clayton's) control head
1	316-85125-00	T2000 Plate cover
1	219-02907-00	Power/ Speaker cable (no plug pack)
1	M2004-00-000-315	Installation manual
1	252-00010-49	Microphone clip
1	302-05211-00	Head mounting bracket
2	350-01007-00	Head thumb screws
4	360-01057-00	Screw hole covers

a. For more information about the X2H221 or X2H241 Primary Control Head, see Part B of this manual.

b. For more information about the X2AM01 T2020/40 Multi-Control Head Radio Interface board, see Part C of this manual.

This kit provides the Primary control head as well as the Radio Interface PCB. This PCB is housed inside a dummy (Clayton's) control head and replaces the standard control head on the radio. The radio can be concealed if required, as all radio controls are now done via the Primary control head.

A speaker and microphone are not provided as part of the Primary Multi-Control Head Kit, as the Primary control head uses the speaker and microphone already supplied with the radio.

T2004-A21 and T2004-A41 Secondary Multi-Control Head Kit Parts

The T2004-A21 or T2004-A41 Secondary Multi-Control Head Kit parts are listed below:

Qty	IPN	Description
1	X2H222 or X2H242	T2020 or T2040 Secondary Control Head ^a
1	219-02900-00	Micromatch to RJ45 cable
1	240-04051-00	RJ45 Screw Terminal Wallbox
2	349-00010-33	Screw, #6*3/4: S/T P/P (bracket to wall)
1	005-00000-40	T2000 Speaker Kit (incl. mount)
1	252-00010-76	T2000 microphone
1	219-02907-00	Power/ Speaker cable (no plug pack)
1	M2004-00-000-315	Installation manual
1	252-00010-49	Microphone clip
1	302-05211-00	Head mounting bracket
2	350-01007-00	Head thumb screws

a. For more information about the X2H222 or X2H242 Secondary Control Head, see Part B of this manual.

This kit provides one Secondary control head and other equipment needed to install the control head for use with the radio. Between one and four Secondary Multi-Control Head Kits can be installed as part of your system.

Each control head can be installed anywhere on a multi-drop line up to 2000M long, and is powered locally by a mains-operated DC plug pack. A speaker plugs into each control head to provide local Rx audio and Tx audio from other control heads in the system.

DC Plug packs for powering multi-control heads

Each multi-control head requires a separate DC plug pack. This is not supplied as part of the kit because the exact plug pack requirements differ between countries.

With each T2004 multi-control head kit you can order one of the following plug packs

Order Code	Input Voltage	Country
T952-012	230V	Australia/ New Zealand
T952-022	230V	United Kingdom
T952-032	230V	Europe
T952-042	110V	United States of America

2.4 System Connections

Each control head connects to the system network via the Micromatch to RJ45 Cable, which plugs into the RJ45 Wallbox. The RJ45 Wall boxes are fitted at intervals along a multi-drop cable.

The radio also connects to the system network via the Micromatch to RJ45 Cable, which plugs into the X2AM01 Multi-Head Radio Interface. The other end of the cable plugs into an RJ45 Wallbox, which is fitted at one end of the multi-drop cable. See system diagram earlier for block overview of system.

3 System Installation

The T2004 Multi-Control Head Installation Manual M2004-00-000-315 should be referred to for the installation process.

4 System Operation

The primary control head provides the same user functionality as the original T2020/T2040 control head, including the On/Off power control to the entire multi-head system.

The Secondary control heads have the same functionality except for the On/Off power control. The power switch is disabled in the Secondary heads, because only one control head (Primary) can provide system power On/Off control.

Secondary control heads can not be individually powered off.

Note The DC plug pack for the Secondary head should be connected to a 24-hour mains outlet in order for the Secondary heads to always function correctly. Display errors will occur if power is removed and replaced without resetting the radio via the Primary head. Secondary heads have a programmed delay of 10 seconds from initial power on, where key presses will not be actioned.

5 System Equipment Specifications

5.1 Multi-Drop Cable Specifications

Note This cable is not supplied by TEL as part of the Multi-Control Head system.

The Multi-Drop Cable is a 4x twisted pair overall screen cable (Cat5 or similar) which is used for cabling within the building. The length of this cable can be a maximum of 2000M.

The recommended cable type used for the multi-drop cable is M&M cables b2004 ESCS 4 x twisted pair/overall screen.

RJ45 Wall boxes are fitted at intervals along this multi-drop cable, which provide the junction between the remote control heads and connection to the building network.

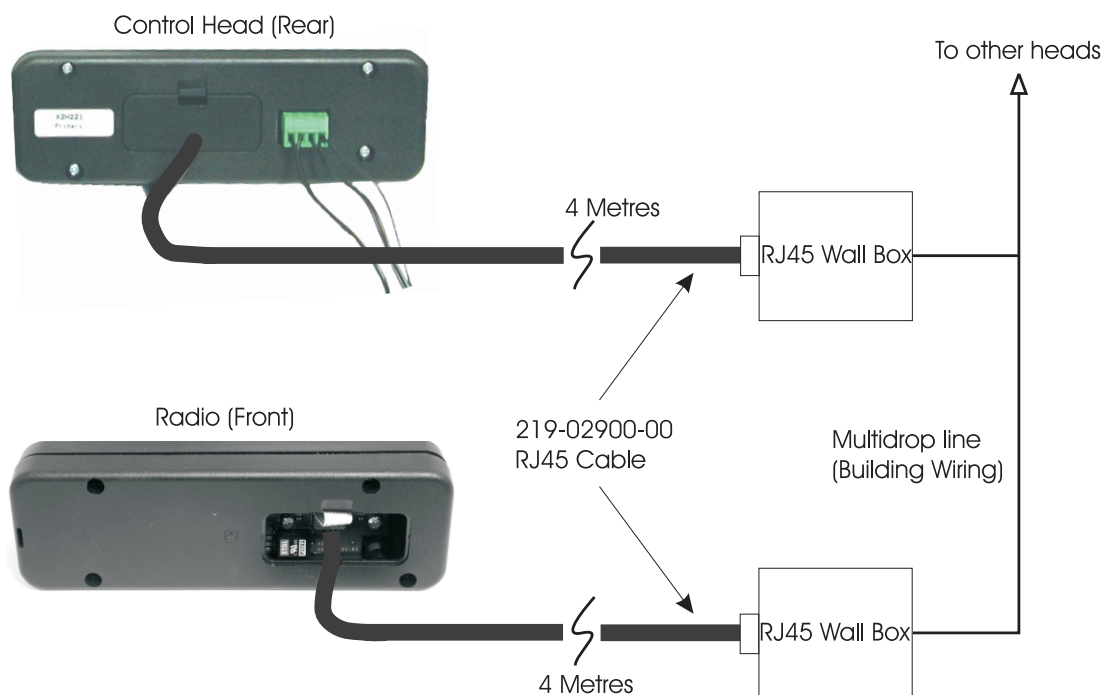

5.2 Micromatch to RJ45 Cable (IPN 219-02900-00)

The Micromatch to RJ45 Cable is the means by which the radio and control heads connect to the building network.

The cable connects the radio at SK3 on the X2AM01 Multi-Head Interface PCB to the radio's RJ45 Wallbox. The cable connects each control head at J5 to the corresponding RJ45 Wallbox.

The table below shows the pin assignment for the RJ45 cable which connects to the wallboxes:



Pin	Colour	Description
1	Black	Data from radio 1B
2	Brown	Data from radio 1A
3	Red	Ground
4	Orange	Balanced audio
5	Yellow	Balanced audio
6	Green	Power switch
7	Blue	Data to radio 2B
8	Violet	Data to radio 2A

5.3 RJ45 Wallbox

Wall boxes are connected in a multi drop arrangement (i.e. all wires are connected in parallel), with one wallbox for each control head and one wallbox for the radio. View below of the RJ45 Wallbox terminals is from the top.

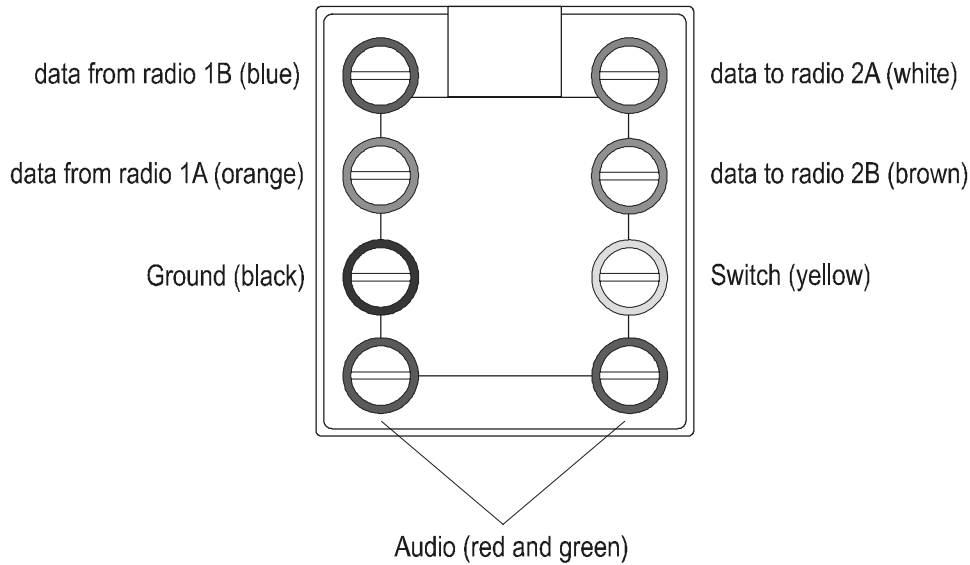

The following pins should be paired:

- Power Switch line and Ground
- Audio
- Data 1A & 1B
- Data 2A & 2B



Note Polarity of the data pairs is important. Earthing of the cable screen should only occur at the radio interface wallbox.



Note Some Cat 5 cable installations (normally used for network or PABX connection) have pin reversal on some or all pins. Check connection polarities if control heads do not function as expected.

5.4 DC Power and Speaker connections

The control head is connected to the external speaker and the DC plug pack via the 219-02907-00 Multi-head DC power cable.

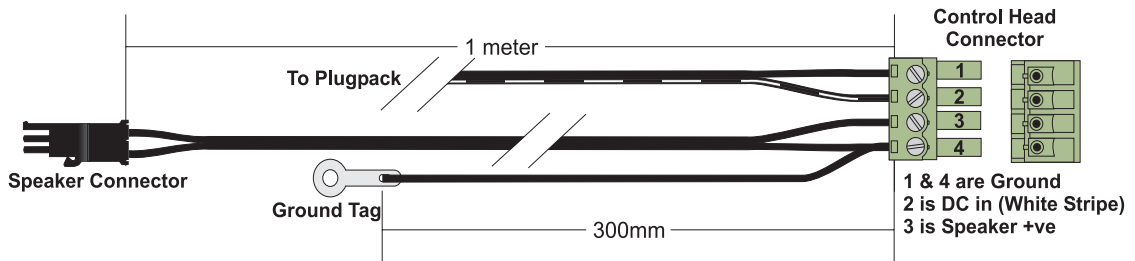

Quantity	IPN	Description
300mm	201-00030-10	Wire T/C 7/0.2mm Pvc Blk
1 meter	205-00010-03	Cable twin cycle 2/7/0.2mm black
1	240-02011-35	Connector 4w Phoenix MCV 1,5/4-G-3,81 4 way jack
1	240-04021-63	Connector 2w 24awg black inline
1	356-00010-05	Tag Solder 4mm long M6144/4.2

6 System Testing

Install all interface boards, control heads and components as per the installation guide (IPN M2004-00-100-315).

Power up all control heads, followed by the radio. Check the Primary control head causes the radio and all heads to power on and off.

Check all control heads show the same information in the LCD

Check all control heads keypad functionality.



Note Secondary head user input is disabled for 10 seconds after power on.

Check transmit and receive audio functionality from all control heads. The radio should function normally from each control head.

If Global mute is enabled check the following

- All control heads have audio when all mics are on hook (Hang up stud is earthed)
- When one microphone is lifted off hook the audio remains enabled for that head and all other heads are muted.
- When a microphone is off hook in the system, check that lifting another microphone off hook enables audio for that head.

Verify the radio can be read/ programmed by a computer connected to any remote head.

7 System Fault Finding

Problem

System will not power up, all heads appear dead.

Suggestion

- Check radio has power connected and two micromatch connectors on the interface board are not reversed.
- Check pin 1 of interface board SK3 appears at J5 pin 1 at control heads. SK3 pin 2 connects to J5 pin 2 etc.
- Check for 13.8V at control heads.
- Check Primary head is correctly fitted and turned on.

Problem

System will not power off.

Suggestion

- Check all multi-drop wiring for shorts or faults.
- Check only one Primary head is installed.

Problem

Head displays information but keypad, mic, etc. are dead.

Suggestion

- This happens for ten seconds after power up on Secondary heads only.
- If condition is permanent check data pair 2A/2B paying attention to polarity.

Problem

Transmit/ Receive audio is very quiet.

Suggestion

Check for cable losses or faults. Max multi drop line length is 2km.

Problem

Transmit/ Receive audio is excessively noisy.

Suggestion

- Confirm radio is OK by removing multi-drop network and connecting a Primary control head directly to the interface board SK3.
- If problem is in the network, check for cable faults, remove noise sources or re-route cable away from noise sources.
- Ensure mic clip is isolated from metal work to avoid earth loops.

Problem

Global mute is not functioning.

Suggestion

- Check JP1 is fitted in the control head.
- Check microphone clip is correctly earthed.

Problem

Control head only shows 2372A510 on power on or all digits and LEDs flash.

Suggestion

- One of the keys on the keypad is stuck down.
- Keypad PCB has become contaminated with chemicals or liquids.

Part B T2004 Control Heads

This part provides general and technical information about the T2020 and T2040 Primary and Secondary control heads used in the T2004 Multi-Control Head system.

The control heads covered in this section are:

- X2H221 T2020 Primary Control Head
- X2H222 T2020 Secondary Control Head
- X2H241 T2040 Primary Control Head
- X2H242 T2040 Secondary Control Head

The following topics are covered in this part:

- Section 1 Introduction
- Section 2 Circuit Description
- Section 3 Functionality
- Section 4 I/O Connections
- Section 5 Assembly/Disassembly Instructions
- Section 6 X2H2xx PCB Information
- Section 7 Testing the X2H2xx control heads

1 Introduction

1.1 The T2004 Control Heads

The T2004 Multi-Control Head system allows the use of between one and five control heads with a single T2020 or T2040 radio. The control heads are configured as one Primary and up to four Secondary. The Primary control head is the only one which controls the radio's power, as well as power to each Secondary control head, otherwise the functionality of all the control heads is the same.

1.2 Features

The remote control heads provide the same functionality as the standard T2000 control head, except it does not provide for a DTMF module to be fitted. If DTMF dialling capability is required, a T2000-A07 DTMF microphone is required.

In addition, the remote control heads provide two extra functions:

- Power Switch Selection (Primary/ Secondary mode selection)
- Global Mute

Power Switch Selection

The Power Switch Selection function is provided so that only one control head in the system (the Primary head) is able to control the system's power. This function is selectable by the fitting of a jumper (JP2) on the control head PCB of the Primary head. This is factory fitted by default.

Only the Primary head should have JP2 fitted. The system will not power on correctly if more than one control head in the system has this jumper fitted.

Global Mute

The Global Mute function is provided to avoid the possibility of audio feedback when two or more control heads are placed in close proximity (for example, within the same room or the same vehicle). The Global Mute function is individually selectable on each control head, via a link on the control head PCB. This is factory fitted by default.

If a control head has this jumper fitted, its speaker will only unmute when the microphone is taken off hook (i.e. to answer or make a call). All other

control heads with the global mute function enabled will mute their speakers. If all microphones are on-hook then all the speakers will unmute when a call is received. A user shall be able to join a conversation by picking up the microphone. This will unmute the speaker audio at that control head.

With Global Mute disabled (i.e. the jumper is not fitted), received audio is present at all control heads, and transmit audio is heard at all heads except the head that is transmitting.

Not all control heads in the system must be set to the same Global Mute setting. For example:

- Where a despatcher station has two control heads in the same room, both heads would need Global Mute enabled to avoid audio feedback.
- Where a supervisor may have a control head installed in their office, and wants to hear all incoming and outgoing traffic, Global Mute would not be enabled. Note that in this example, outgoing transmit audio from this control head would be heard at the despatcher's station heads.

General Specifications

Radios supported	Series II T2020 and T2040 radios
Possible number of control heads	Between one and five
Control head DC supply & Speaker connector	Phoenix MCV 1,5/4-G-3,81 4 way jack
Control head DC supply voltage (at 800mA)	+13.8V nominal +10.8V minimum +16.0V maximum
Balanced line audio levels	Preset to -10dBm for receiver audio Preset to -15dBm for transmitter audio
Control head dimensions	Standard T2000 control head dimensions

1.3 Product Codes

Product Code	Description	TCL Code
T2004-A20	T2020 Primary Multi-Control Head Kit	
T2004-A21	T2020 Secondary Multi-Control Head Kit	
T2004-A40	T2040 Primary Multi-Control Head Kit	
T2004-A41	T2040 Secondary Multi-Control Head Kit	
X2H221	T2020 Primary Control Head only	STA6682-4H
X2H222	T2020 Secondary Control Head only	STA6682-4H
X2H241	T2040 Primary Control Head only	STA6682-4H
X2H242	T2040 Secondary Control Head only	STA6682-4H
X2AM01	T2020/40 Multi-Control Head Radio Interface PCB	STA6682-1H

2 Circuit Description

This section provides circuit information for the T2004 Primary and Secondary control heads as shown in the X2H2xx control head block diagram.

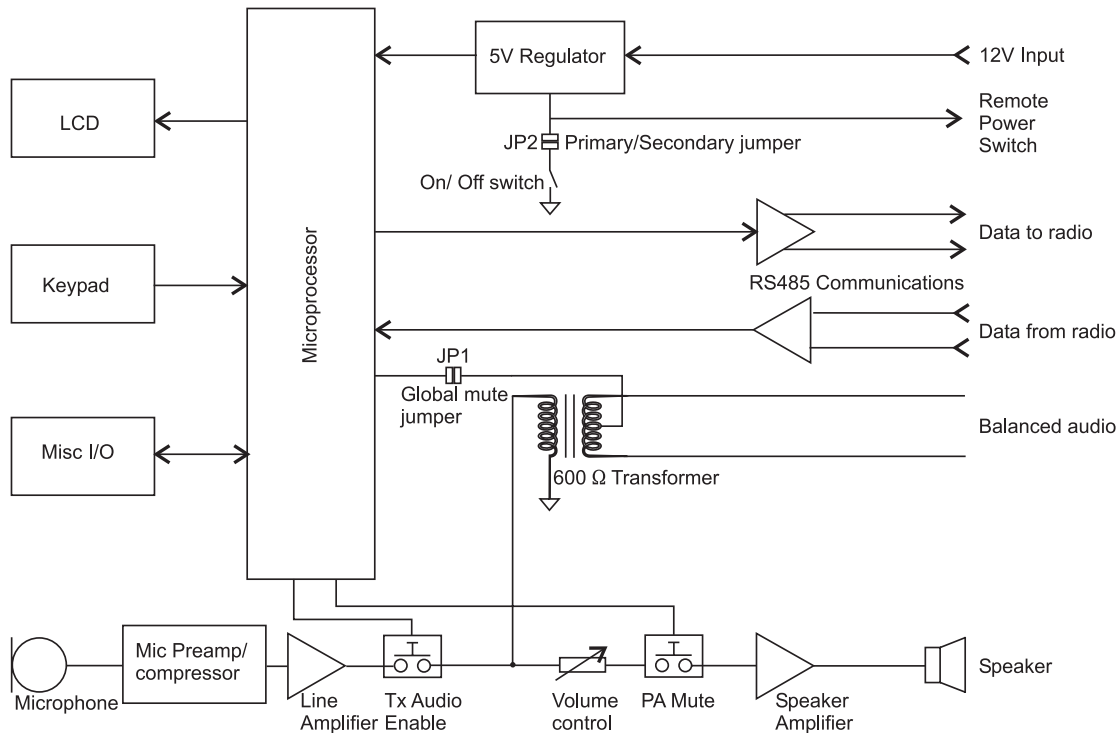

Audio

An internal power amplifier drives a speaker connected to the control head for local audio.

The PCB provides a 600 Ohm interface for both the Tx and Rx audio. A microphone amplifier/ compressor followed by a line driver stage outputs microphone audio to the balanced line.

Microphone

The standard T2000-A02 microphone is used.

Power

The control head is supplied with 13.8V from an AC to DC plug pack. The remote power switch line J5-3 (controlled by the Primary control head) controls the 5V regulators on the Secondary heads and interface board.

Data

A separate RS-485 transmitter and receiver in each control head provide the data communications between the radio and control heads.

Connections

Connection to the remote control heads is via the micromatch to RJ45 cable at J5, which connects to the RJ45 Wallbox. The wallbox connects to the multi-drop cable, which connects to the RJ45 Wallbox for each control head and the radio.

DC Input and speaker output is via a 4 way phoenix connector at J6. The supplied cable 219-02907-00 connects to J6. The plug pack (supplied separately) connects to this cable assembly.

The DC input is polarity protected so that in the event of reverse polarity being applied the head will not function, no damage will occur.

3 Functionality

3.1 Software

Software version 2372A510 is programmed into the microprocessor on all of the remote control heads.

The software allows the remote control heads to work in the same way as standard T2000 control heads, with additional features detailed below.

Primary Secondary Configuration

The control head design is altered to allow a system of multiple heads to function with one radio. The heads are divided into Primary and Secondary via hardware, i.e. by linking a port bit on the head processor (Secondary = high, Primary = low). Only one Primary is possible per system.

RS485

The serial line driver in each head feeds its output to a common serial line back to the radio. This raises the problem of multiple devices trying to drive one line. To overcome this, the RS485 line drivers are held in a tri-state condition until the head generates serial data. Hardware on the circuit board enables the driver at the appropriate time. The radio can still be programmed from a PC via any head.

Avoiding Data Clashes

The heads share a common serial data link with the radio, so in order to overcome data clashes at power up time, Secondary heads have a 10 second timeout during which all user input and all serial output is stopped. After the timeout, normal operation resumes.

Note that there is no mechanism to prevent data clashes during normal operation; the system must rely on the probability of a clash being very small.

Controlling the Speaker Path

Muting the speaker output of one head by another head is accomplished in hardware by phantoming a DC control signal onto commonly connected audio lines which link all heads in the group. This line can be either driven or its state sensed by the head microprocessor and the audio output is

controlled accordingly. This is enabled by fitting JP1, for the Global Mute feature.

In order to accomplish this, some I/O lines of the microprocessor have been reassigned to new functions. The control of the audio output is based on a truth table that uses the state of the PTT, Hook and Line Sense inputs as its control elements.

The audio truth table is shown below.

Scenario (All heads in this condition)	JP1 (In = Global Mute Active)	PTT (0= Active i.e Transmitting)	Hook Switch (1= On hook)	Global Mute Line Drive (1= mute other heads)	Global Mute Line Sense (1= activate mute)	Spkr Mute (1=mute active i.e.no audio)	Comment
On hook, no Rx audio	IN	1	1	0	0	0	
On hook, no Rx audio	OUT	1	1	0	0	0	
On hook, Rx audio	IN	1	1	0	0	0	Everyone can hear audio
On hook, Rx audio	OUT	1	1	0	0	0	Everyone can hear audio
Off hook (local)	IN	1	0	1	1	0	Only local head has Rx audio
Off hook (local)	OUT	1	0	0	1	0	Because jumper is out, line drive does not affect other heads
Off hook (remote)	IN	1	1	0	1	1	Everyone else muted
Off hook (remote)	OUT	1	1	0	0	0	Hear everything
Off hook (local+remote)	IN	1	0	1	1	0	Everyone off hook hears audio
Off-hook (local+remote)	OUT	1	0	0	1	0	Hear everything
PTT (local) off hook	IN	0	1	1	1	1	Mute local
PTT (local) off hook	OUT	0	1	0	1	1	Mute local
PTT (local) on hook	IN	0	1	1	1	1	All muted
PTT (local) on hook	OUT	0	1	0	1	1	Mute local but no-one else
PTT (remote) on hook local	IN	1	1	0	1	1	Mute local (same as 'Off hook remote')
PTT (remote) on hook local	OUT	1	1	0	1	0	Hear everything
PTT (remote) off hook local	IN	1	0	1	1	0	Hear everything
PTT (remote) off hook local	OUT	1	0	0	1	0	Hear everything

4 I/O Connections

This section describes the I/O connections on the board.

4.1 J6: Power and Speaker Connector

J6 on the rear panel of the control head provides connections for power, speaker and microphone clip ground. The connector provides screw terminals for fitting the microphone clip earth wire and speaker wires.

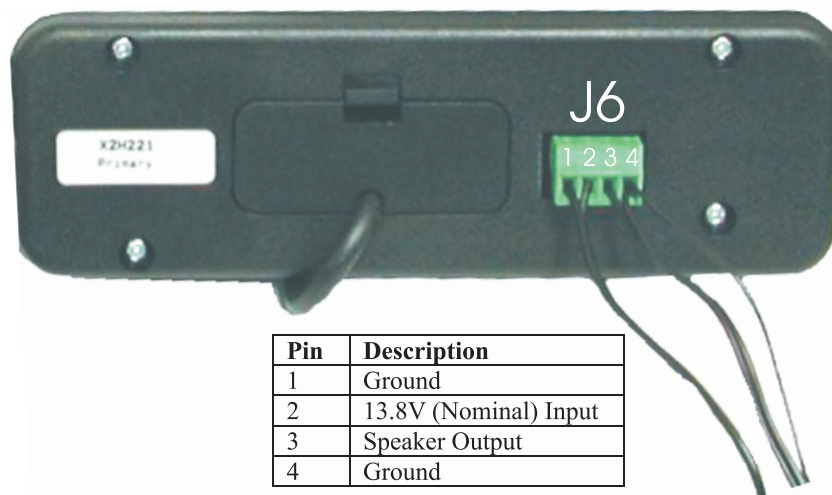

4.2 J5: 8way Micromatch Socket

Pin	Signal	Description
1	Tx Data 2A	Data to radio A
2	Tx Data 2B	Data to radio B
3	Pwr Sw	Remote power switch, low = power on
4	Audio	Balanced audio line
5	Audio	Balanced audio line
6	Gnd	Common ground
7	Rx Data 1A	Data from radio A
8	Rx Data 1B	Data from radio B

4.3 S10: 6way RJ Socket (Microphone)

Pin	Signal	Description
1	+13V8	Low current supply for programming interface
2	TXD	Data from radio to computer
3	PTT	low = transmit condition
4	MIC	Microphone audio
5	GND	Common ground
6	RXD	Data from computer to radio

5 Assembly/Disassembly Instructions

This section provides mechanical parts information and disassembly instructions for the control heads.

5.1 Mechanical Parts

The T2004 Multi-Control Head includes the following mechanical parts. Please use the IPN number and description when ordering replacement parts.



Note All PCB and cable components are specified separately. For information for these items, refer to the sections listed below:

- For PCB information, refer to Section 6, “X2H2xx PCB Information”.
- For external cable information, refer to Part A, Section 5, “System Equipment Specifications”.

Item	Description	IPN	Qty
1	Knob A3M2530 T2K SII	311-01042-01	1
2	Microphone with Grommet	252-00010-76	1
3	Panel Frt Scrn T2020/40/50 SII	316-06430-02	1
4	Volume Pot Nut	part of 040-05100-20	1
5	Volume Pot Washer	part of 040-05100-20	1
6	LCD Display	008-02029-00	1
7	Lightspreader 20 Bttm T2K SII	304-07036-02	1
8	Keypad SII International	311-03076-01(T2020) 311-03078-01(T2040)	1
9	Volume Pot	040-05100-20	1
10	Pot PCB	part of 228-23722-xx	1
11	Microphone Connector	240-04021-61	1
12	Lens LCD Display T2K FM2/TR2	312-01046-05	1
13	Control Head PCB	228-23722-xx	1
14	Screw 4-20x3/8 P/P Trilobe-P BZ (Control Head Screws)	349-00010-22	2
15	Back Panel	316-02001-00	1
16	Screw 4-20x5/8 P/P Trilobe-P BZ (Remote Back Screws)	349-00010-24	4
17	Captive Nut M4 Pressed	352-00010-17	2
18	Remoting Connector Cover	316-85125-00	1

5.2 Disassembling the Control Head

To disassemble the control heads, refer to the parts list opposite, and the instructions and illustration below.

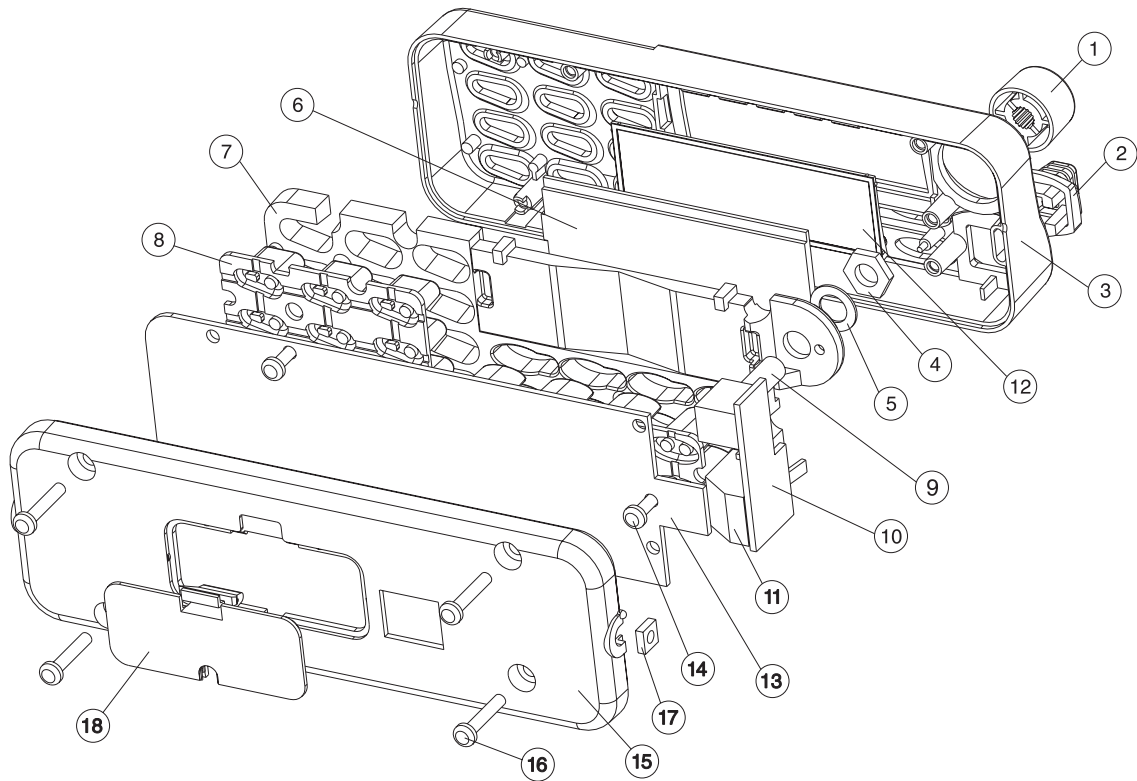

1. Remove the four retaining screws(16) and two captive nuts (17) from the back panel.
2. Remove the two retaining screws (14) from the control head PCB.



Note When replacing the screws, tighten to a torque of 8in.lb (0.9N).

3. With the control head face down, gently remove the PCB (13), keypad (8), and light spreader (7) from the front panel (3)



Caution Do not disturb the positioning or height of the LEDs, as this is critical for reassembly.

4. Carefully remove the LCD (6) and lens (12).
5. Lay the assembly on a horizontal surface, with the light spreader (7) in place.
6. Remove the volume knob (1) and volume knob nut (4) to access the lightspreader and keypad.
7. Before reassembly, the LCD and PCB edge connectors should be wiped with alcohol.



Caution

Take care to ensure the alcohol does not come into contact with the coating on the lightspreader, as this will dissolve on contact with alcohol.

6 X2H2xx PCB Information

This section contains all PCB information for the X2H2xx Multi-Head Control Head PCB.

The following information is included:

- PCB parts list
- Grid references
- PCB layout drawings for both sides of the board
- Circuit diagram.

6.1 X2H221 Rev 007 Parts List

IPN 228-23722-02

Ref	IPN	Description	Ref	IPN	Description
BF1	008-00010-25	LED 2mm Grn Tower 3.8 Base	C53	016-09100-03	Cap Elec SMD 100u 16v 20%
BF2	008-00010-25	LED 2mm Grn Tower 3.8 Base	C55	015-23100-01	Cap Cer 0805 100p 5% NPO 50v
BF3	008-00010-25	LED 2mm Grn Tower 3.8 Base	C56	015-22330-01	Cap Cer 0805 33p 5% NPO 50v
BF4	008-00010-25	LED 2mm Grn Tower 3.8 Base	C57	016-09100-03	Cap Elec SMD 100u 16v 20%
BF5	008-00010-25	LED 2mm Grn Tower 3.8 Base	C58	015-27100-10	Cap Cer 0805 1m+80-20% Y5v 16v
BF6	008-00010-25	LED 2mm Grn Tower 3.8 Base	C59	015-23100-01	Cap Cer 0805 100p 5% NPO 50v
BF7	008-00010-25	LED 2mm Grn Tower 3.8 Base	C62	015-26100-08	Cap Cer 0805 100n 10% X7r 50v
BF8	008-00010-25	LED 2mm Grn Tower 3.8 Base	C67	015-26100-08	Cap Cer 0805 100n 10% X7r 50v
BL1	008-00020-31	LED 3mm Yel Clear Sunpwr	C731	015-25100-08	Cap Cer 0805 10n 10% X7r 50v
BL2	008-00020-31	LED 3mm Yel Clear Sunpwr	C732	015-25100-08	Cap Cer 0805 10n 10% X7r 50v
BL3	008-00020-31	LED 3mm Yel Clear Sunpwr	C733	015-25220-08	Cap Cer 0805 22n 10% X7r 50v
BL4	008-00020-31	LED 3mm Yel Clear Sunpwr	C734	015-24100-08	Cap Cer 0805 1n 10% X7r 50v
BL5	008-00020-31	LED 3mm Yel Clear Sunpwr	D1	001-10001-60	Diode SMD BAS16
C1	016-08100-03	Cap Elec SMD 10uF 35V 105/2000	D2	001-10070-01	Diode BAV70W Dual Ss SOT323
C2	015-27100-10	Cap Cer 0805 1m+80-20% Y5v 16v	D3	001-10001-60	Diode SMD BAS16
C3	016-09100-03	Cap Elec SMD 100u 16v 20%	D4	001-10001-60	Diode SMD BAS16
C4	015-25220-08	Cap Cer 0805 22n 10% X7r 50v	D5	001-10011-74	Diode SMD MRA4004T3 1a/400v
C5	015-24100-08	Cap Cer 0805 1n 10% X7r 50v	J4	240-00020-87	Hdr 2x5w Ra Pcb Mtg
C6	016-09100-03	Cap Elec SMD 100u 16v 20%	J5	240-10000-05	Conn SMD 8w 2r Skt M/Match
C7	015-26100-08	Cap Cer 0805 100n 10% X7r 50v	J6	240-06000-00	Conn 4W Hdr Vrt3.81mm Combicon
C8	015-24100-08	Cap Cer 0805 1n 10% X7r 50v	JP1	036-10000-00	Res M/F SMD 0805 0e 0.125w
C9	015-27100-10	Cap Cer 0805 1m+80-20% Y5v 16v	JP2	036-10000-00	Res M/F SMD 0805 0e 0.125w
C10	016-08100-01	Cap Elec SMD 10m 4*5.2 16v 20%	LCD1	008-02029-00	LCD 8 Chr 14 Seg Alpha T2K
C15	015-25150-08	Cap Cer 0805 15n 10% X7r 50v	PT501	040-05100-20	Pot 10k Log 3a 16vDC Spst Pcb
C20	015-26100-08	Cap Cer 0805 100n 10% X7r 50v	Q1	000-10008-17	Xstr SMD BC817-25 NPN SOT23
C21	015-26100-08	Cap Cer 0805 100n 10% X7r 50v	Q2	000-10008-17	Xstr SMD BC817-25 NPN SOT23
C22	015-26100-08	Cap Cer 0805 100n 10% X7r 50v	Q3	000-10008-17	Xstr SMD BC817-25 NPN SOT23
C23	015-26100-08	Cap Cer 0805 100n 10% X7r 50v	Q4	000-10085-71	Xstr SMD BC857BW PNP SOT323
C24	015-26100-08	Cap Cer 0805 100n 10% X7r 50v	Q5	000-10008-17	Xstr SMD BC817-25 NPN SOT23
C25	015-22100-01	Cap Cer 0805 10p+-0.5p NPO 50v	Q6	000-10085-71	Xstr SMD BC857BW PNP SOT323
C26	015-26100-08	Cap Cer 0805 100n 10% X7r 50v	Q7	000-10008-17	Xstr SMD BC817-25 NPN SOT23
C27	015-23100-01	Cap Cer 0805 100p 5% NPO 50v	Q8	000-10085-71	Xstr SMD BC857BW PNP SOT323
C28	015-26100-08	Cap Cer 0805 100n 10% X7r 50v	Q9	000-10008-17	Xstr SMD BC817-25 NPN SOT23
C29	015-23150-01	Cap Cer 0805 150p 5% NPO 50v	Q10	000-10008-17	Xstr SMD BC817-25 NPN SOT23
C30	015-23150-01	Cap Cer 0805 150p 5% NPO 50v	Q11	000-10008-17	Xstr SMD BC817-25 NPN SOT23
C31	015-23150-01	Cap Cer 0805 150p 5% NPO 50v	R1	036-16100-00	Res M/F SMD 0805 100k 5%
C32	015-23150-01	Cap Cer 0805 150p 5% NPO 50v	R5	036-15270-00	Res M/F SMD 0805 27k 5%
C33	015-23150-01	Cap Cer 0805 150p 5% NPO 50v	R6	036-16100-00	Res M/F SMD 0805 100k 5%
C34	015-26100-08	Cap Cer 0805 100n 10% X7r 50v	R7	036-15100-10	Res M/F SMD 0805 10k 1%
C35	015-24470-08	Cap Cer 0805 4n7 10% X7r 50v	R8	036-14470-10	Res M/F SMD 0805 4k7 1%
C36	015-25150-08	Cap Cer 0805 15n 10% X7r 50v	R09	036-17100-00	Res M/F SMD 0805 1m 5%
C37	015-24470-08	Cap Cer 0805 4n7 10% X7r 50v	R10	036-16100-00	Res M/F SMD 0805 100k 5%
C38	015-22220-05	Cap 0805 22p 1% 200v	R11	036-16100-00	Res M/F SMD 0805 100k 5%
C39	015-22220-05	Cap 0805 22p 1% 200v	R12	036-16100-00	Res M/F SMD 0805 100k 5%
C40	015-23150-01	Cap Cer 0805 150p 5% NPO 50v	R13	036-16100-00	Res M/F SMD 0805 100k 5%
C41	015-26100-08	Cap Cer 0805 100n 10% X7r 50v	R14	036-16100-00	Res M/F SMD 0805 100k 5%
C42	015-26100-08	Cap Cer 0805 100n 10% X7r 50v	R15	036-15270-00	Res M/F SMD 0805 27k 5%
C43	015-26100-08	Cap Cer 0805 100n 10% X7r 50v	R16	036-16100-00	Res M/F SMD 0805 100k 5%
C44	016-07470-01	Cap Elec SMD 4u7 6*4 16v 20%	R17	036-15180-00	Res M/F SMD 0805 18k 5%
C45	015-24100-08	Cap Cer 0805 1n 10% X7r 50v	R18	036-15560-10	Res M/F SMD 0805 56k 1%
C46	015-24100-08	Cap Cer 0805 1n 10% X7r 50v	R19	036-14100-00	Res M/F SMD 0805 1k 5%
C47	016-08470-01	Cap Elec SMD 47uf 6*4 16v	R20	036-16100-00	Res M/F SMD 0805 100k 5%
C48	015-26100-08	Cap Cer 0805 100n 10% X7r 50v	R21	036-15470-10	Res M/F SMD 0805 47k 1%
C49	015-26100-08	Cap Cer 0805 100n 10% X7r 50v	R22	036-15100-10	Res M/F SMD 0805 10k 1%
C50	015-27100-10	Cap Cer 0805 1m+80-20% Y5v 16v	R23	036-15100-10	Res M/F SMD 0805 10k 1%
C51	015-27100-10	Cap Cer 0805 1m+80-20% Y5v 16v	R24	036-15270-00	Res M/F SMD 0805 27k 5%
C52	016-07220-06	Cap Elec SMD Bi-P 22u 16v 20%	R25	036-15100-10	Res M/F SMD 0805 10k 1%

Ref	IPN	Description	Ref	IPN	Description
R26	036-15100-10	Res M/F SMD 0805 10k 1%	R142	036-15150-10	Res M/F SMD 0805 15k 1%
R28	036-10000-00	Res M/F SMD 0805 0e 0.125w	R143	036-15270-00	Res M/F SMD 0805 27k 5%
R34	036-14470-10	Res M/F SMD 0805 4k7 1%	R144	036-12390-00	Res M/F SMD 0805 39e 5%
R35	036-14470-10	Res M/F SMD 0805 4k7 1%	R145	036-15270-00	Res M/F SMD 0805 27k 5%
R42	036-15470-10	Res M/F SMD 0805 47k 1%	R146	036-10000-00	Res M/F SMD 0805 0e 0.125w
R43	036-15470-10	Res M/F SMD 0805 47k 1%	R147	036-14100-00	Res M/F SMD 0805 1k 5%
R44	036-15470-10	Res M/F SMD 0805 47k 1%	R148	036-15100-10	Res M/F SMD 0805 10k 1%
R53	036-15470-10	Res M/F SMD 0805 47k 1%	R149	036-15100-10	Res M/F SMD 0805 10k 1%
R69	036-15470-10	Res M/F SMD 0805 47k 1%	R595	036-12100-10	Res M/F SMD 0805 10e 1%
R79	036-15470-10	Res M/F SMD 0805 47k 1%	RLY2	002-10117-00	IC SMD TS117 Opto 8p Fpak
R80	036-15100-10	Res M/F SMD 0805 10k 1%	S10	240-04021-61	Skt 6w Phone Jack S-Ent
R81	036-15100-10	Res M/F SMD 0805 10k 1%	S11	240-00020-87	Hdr 2x5w Ra Pcb Mtg
R82	036-15100-10	Res M/F SMD 0805 10k 1%	T2	054-00010-20	Xmfr SMD Ct Etal2782
R83	036-15100-10	Res M/F SMD 0805 10k 1%	U1	002-10018-77	IC SMD LM1877M Dual Af Pwr Amp
R84	036-13560-00	Res M/F SMD 0805 560e 5%	U2	002-10003-58	IC SMD LM358 Dual 0-Amp
R85	036-13560-00	Res M/F SMD 0805 560e 5%	U13	240-04020-42	Skt 44 Pin SMD Plcc
R86	036-13560-00	Res M/F SMD 0805 560e 5%	U14	002-10340-64	IC SMD MC34064 L-Volt Sense
R87	036-13560-00	Res M/F SMD 0805 560e 5%	U15	002-74900-04	IC SMD 74HC04D 6x Inv Buffd
R88	036-16180-00	Res M/F SMD 0805 180k 5%	U16	002-74900-04	IC SMD 74HC04D 6x Inv Buffd
R89	036-13470-00	Res M/F SMD 0805 470e 5%	U17	002-10085-76	IC SMD PCF8576T LCD Dvr
R90	036-15100-10	Res M/F SMD 0805 10k 1%	U19	002-10004-83	IC SP483EEN RS485 Xcvr/Esd S08
R91	036-14120-00	Res M/F SMD 0805 1k2 5%	U20	002-10016-51	IC SMD SSM2165-1s Preamp S0-8
R92	036-14270-00	Res M/F SMD 0805 2k7 5%	U21	002-10004-83	IC SP483EEN RS485 Xcvr/Esd S08
R93	036-14100-00	Res M/F SMD 0805 1k 5%	U22	002-12951-00	IC SMD LP2951CM Adj Vltge Reg
R94	036-14270-00	Res M/F SMD 0805 2k7 5%	U23	002-10021-42	IC SMD TLE2142CD Opamp S08
R95	036-14120-00	Res M/F SMD 0805 1k2 5%	X2	274-01070-00	Xtal 4.000MHz Hc-49u/S Lo-Prof
R96	036-14270-00	Res M/F SMD 0805 2k7 5%		002-20068-07	IC MC68HC705C8AFN Otp Micro
R97	036-13470-00	Res M/F SMD 0805 470e 5%		209-01027-00	Strip A3m2544 SI Impregnated
R98	036-13390-00	Res M/F SMD 0805 390e 5%		228-23722-01	Pcb T2020/40 Multi/Ctrl Head
R99	036-13470-00	Res M/F SMD 0805 470e 5%		304-07036-02	Light Sprdr 20 Bttm T2K SII
R100	036-14270-00	Res M/F SMD 0805 2k7 5%		311-01042-01	Knob A3M2530 T2K SII
R101	036-14270-00	Res M/F SMD 0805 2k7 5%		311-03076-01	K/Pad T2020 SII International
R102	036-15470-10	Res M/F SMD 0805 47k 1%		312-01046-05	Lens LCD Dsply T2K FM2/TR2
R103	036-15100-10	Res M/F SMD 0805 10k 1%		316-02001-00	Pnl M/Ctrl Hd Back T2K
R104	036-18100-00	Res M/F SMD 0805 10m 5%		316-06430-02	Pnl Frt Scrn T2020/40/50 SII
R105	036-14330-00	Res M/F SMD 0805 3k3 5%		316-85125-00	Plate Cvr T2K
R106	036-15470-10	Res M/F SMD 0805 47k 1%		365-01516-01	Lbl T2K Model Id T/A
R107	036-15100-10	Res M/F SMD 0805 10k 1%		399-00010-53	Bag Plstc 150*250mm
R108	036-15100-10	Res M/F SMD 0805 10k 1%		349-00010-22	Scrw 4-20x3/8 P/P Trilobe-P BZ
R109	036-15100-10	Res M/F SMD 0805 10k 1%		352-00010-17	Nut M4 Pressed Sq S/T Bz
R110	036-15100-10	Res M/F SMD 0805 10k 1%		349-00010-24	Scrw 4-20x5/8 P/P Trilobe-P BZ
R111	036-13560-00	Res M/F SMD 0805 560e 5%			
R112	036-13560-00	Res M/F SMD 0805 560e 5%			
R113	036-13560-00	Res M/F SMD 0805 560e 5%			
R114	036-13560-00	Res M/F SMD 0805 560e 5%			
R117	036-13120-00	Res M/F SMD 0805 120e 5%			
R119	036-15100-10	Res M/F SMD 0805 10k 1%			
R120	036-16150-00	Res M/F SMD 0805 150k 5%			
R121	036-14220-00	Res M/F SMD 0805 2k2 5%			
R123	036-13470-00	Res M/F SMD 0805 470e 5%			
R124	036-13470-00	Res M/F SMD 0805 470e 5%			
R125	036-15470-10	Res M/F SMD 0805 47k 1%			
R126	036-15470-10	Res M/F SMD 0805 47k 1%			
R127	036-14470-10	Res M/F SMD 0805 4k7 1%			
R128	036-15270-00	Res M/F SMD 0805 27k 5%			
R129	036-15470-10	Res M/F SMD 0805 47k 1%			
R130	036-15220-10	Res M/F SMD 0805 22k 1%			
R133	036-16270-00	Res M/F SMD 0805 270k 5%			
R135	036-13120-00	Res M/F SMD 0805 120e 5%			
R136	036-13120-00	Res M/F SMD 0805 120e 5%			
R138	036-15100-10	Res M/F SMD 0805 10k 1%			
R139	036-15390-00	Res M/F SMD 0805 39k 5%			
R140	036-16220-00	Res M/F SMD 0805 220k 5%			
R141	036-15270-00	Res M/F SMD 0805 27k 5%			

6.2 X2H221 Rev 007 Grid Reference

IPN 228-23722-02

Grid Ref	PCB	Circuit Diagram	Grid Ref	PCB	Circuit Diagram
B0	D4	1F2	C39	K7	1H9
B1	E7	1G2	C40	F6	1D14
B2	D7	1G2	C41	E4	1A1
B3	B7	1G1	C42	E3	1B3
B4	E6	1G2	C43	E4	1B3
B5	D6	1G2	C44	P6	1E6
B6	B6	1G1	C45	E6	1E6
B7	E5	1G2	C46	D6	1D6
B8	D5	1G2	C47	J4	1B6
B9	B5	1G1	C48	D5	1E13
B#	B4	1F1	C49	C6	1D13
B*	E4	1F2	C50	F5	1B1
BF1	N5	1H12	C51	N5	1C4
BF2	M5	1J12	C52	F3	1A3
BF3	K5	1F12	C53	N5	1C5
BF4	H5	1G12	C55	D3	1B4
BF5	N3	1H12	C56	D3	1B4
BF6	M3	1H12	C57	C4	1C3
BF7	K3	1F12	C58	D4	1B5
BF8	H3	1G12	C59	D5	1B5
BL1	K4	1D9	C60	D5	1B6
BL2	C4	1D9	C62	B6	1B11
BL3	C6	1D9	C67	C7	1C13
BL4	F6	1D10	C68	A5	1B13
BL5	P7	1D10	C731	S3	1D2
C1	A7	1C12	C732	R4	1D2
C2	L5	1C6	C733	R4	1D2
C3	A6	1B14	C734	R4	1D1
C4	C6	1E11	D1	D6	1D6
C5	C5	1B11	D2	N6	1D5
C6	B7	1C13	D3	B5	1B9
C7	K7	1J8	D4	G7	1F10
C8	P6	1E6	D5	M5	1C14
C9	A4	1B7	F1	N5	1G5
C10	A5	1B10	F2	L5	1G4
C15	M6	1J7	F3	J5	1G4
C20	B5	1J3	F4	G5	1G3
C21	F4	1B2	F5	N4	1G5
C22	C5	1E12	F6	L4	1G4
C23	D4	1J4	F7	J4	1G4
C24	F8	1J1	F8	G4	1G3
C25	A4	1B8	J4	R5	1E4
C26	L6	1K9	J5	G5	1B7 1C7 1D14 1E14
C27	B4	1B9	J6	L5	1B14
C28	D7	1D12	JP1	G6	1F10
C29	K5	1B14	JP2	F6	1D4
C30	E5	1E13	LCD1	K8	1J13
C31	F6	1D13	P1	G7	1E10
C32	G4	1D13	P2	P5	1H4
C33	E5	1E14	P3	E3	1B3
C34	J4	1H7	PHH1	A4	1A8
C35	D5	1H4	PT501	S1	1D2 1D3
C36	D5	1H5	PTH2	N4	1A9
C37	G5	1H5	PTH3	P4	1A9
C38	K6	1H9	PTH4	P5	1A10

Grid Ref	PCB	Circuit Diagram	Grid Ref	PCB	Circuit Diagram
PTH5	P7	1A10	R95	G4	1E10
PTH6	C3	1A11	R96	G6	1G5
PTH7	B7	1A11	R97	H4	1E9
PTH8	D7	1A12	R98	G4	1D9
Q1	B6	1B11	R99	D5	1H5
Q2	B5	1B10	R100	G6	1G6
Q3	G7	1G9	R101	E5	1H5
Q4	H4	1E9	R102	D5	1H5
Q5	G7	1F10	R103	E6	1H6
Q6	D6	1E11	R104	K6	1H8
Q7	H4	1E9	R105	G7	1E8
Q8	E5	1H6	R106	G7	1F9
Q9	P6	1F6	R107	F7	1G11
Q10	D6	1D6	R108	E7	1G11
Q11	G7	1E9	R109	E7	1F11
R1	H7	1H8	R110	E7	1F11
R4	A6	1B13	R111	H5	1G12
R5	C6	1B11	R112	H4	1G12
R6	C6	1E11	R113	K5	1F12
R7	B5	1B10	R114	J4	1F12
R8	A4	1B7	R117	E4	1B1
R9	A4	1B8	R118	P5	1F5
R10	B4	1B9	R119	E4	1B3
R11	A4	1A7	R120	E4	1B3
R12	B5	1B10	R121	P6	1F6
R13	B4	1B8	R123	D6	1E5
R14	B4	1A8	R124	E6	1E5
R15	B5	1B10	R125	D6	1D6
R16	B6	1B11	R126	D6	1D6
R17	C5	1B8	R127	D6	1E7
R18	A4	1B7	R128	C4	1B3
R19	B5	1B9	R129	D6	1D7
R20	G6	1G10	R130	C4	1C3
R21	G7	1G9	R133	A6	1B13
R22	G7	1F9	R135	C6	1D13
R23	G7	1G10	R136	D5	1E13
R24	G6	1F9	R137	E5	1A1
R25	B6	1B10	R138	M5	1D4
R26	B5	1B11	R139	E4	1A3
R28	R1	1D2	R140	D4	1B4
R34	K6	1J8	R141	D4	1B4
R35	L6	1J8	R142	C4	1C3
R42	J5	1G5	R143	D4	1B5
R43	J5	1G5	R144	J4	1B6
R44	J5	1G6	R145	D5	1B5
R53	J5	1G6	R146	D5	1B6
R69	J5	1G6	R147	K4	1A7
R79	J4	1J7	R148	A6	1B12
R80	E6	1J11	R149	G7	1F8
R81	E7	1H11	R595	S3	1E2
R82	F7	1H11	RLY2	M4	1A6
R83	F7	1G11	S10	S3	1E1
R84	L5	1J12	S11	S3	1E3
R85	L4	1H12	T2	L4	1C7
R86	N5	1H12	U1	B6	1B13
R87	N4	1H12	U13	J6	1G7
R88	L6	1J9	U14	L5	1H6
R89	L6	1K9	U15	F7	1F11 1G11 1K1 1H11
R90	M6	1K9	U16	E6	1E6 1H11 1J11 1K2 1D8 1C7
R91	M6	1K9	U17	M7	1J9
R92	G6	1G6	U19	C5	1E12
R93	G4	1E9	U2	B4	1K3 1B8 1B9
R94	G6	1G5	U20	F4	1A2

Grid Ref	PCB	Circuit Diagram
U21	D7	1D12
U22	M5	1C5
U23	D4	1B6 1K4 1B4
X2	K7	1H8

6.4 228-23722-02 PCB Bottom Side

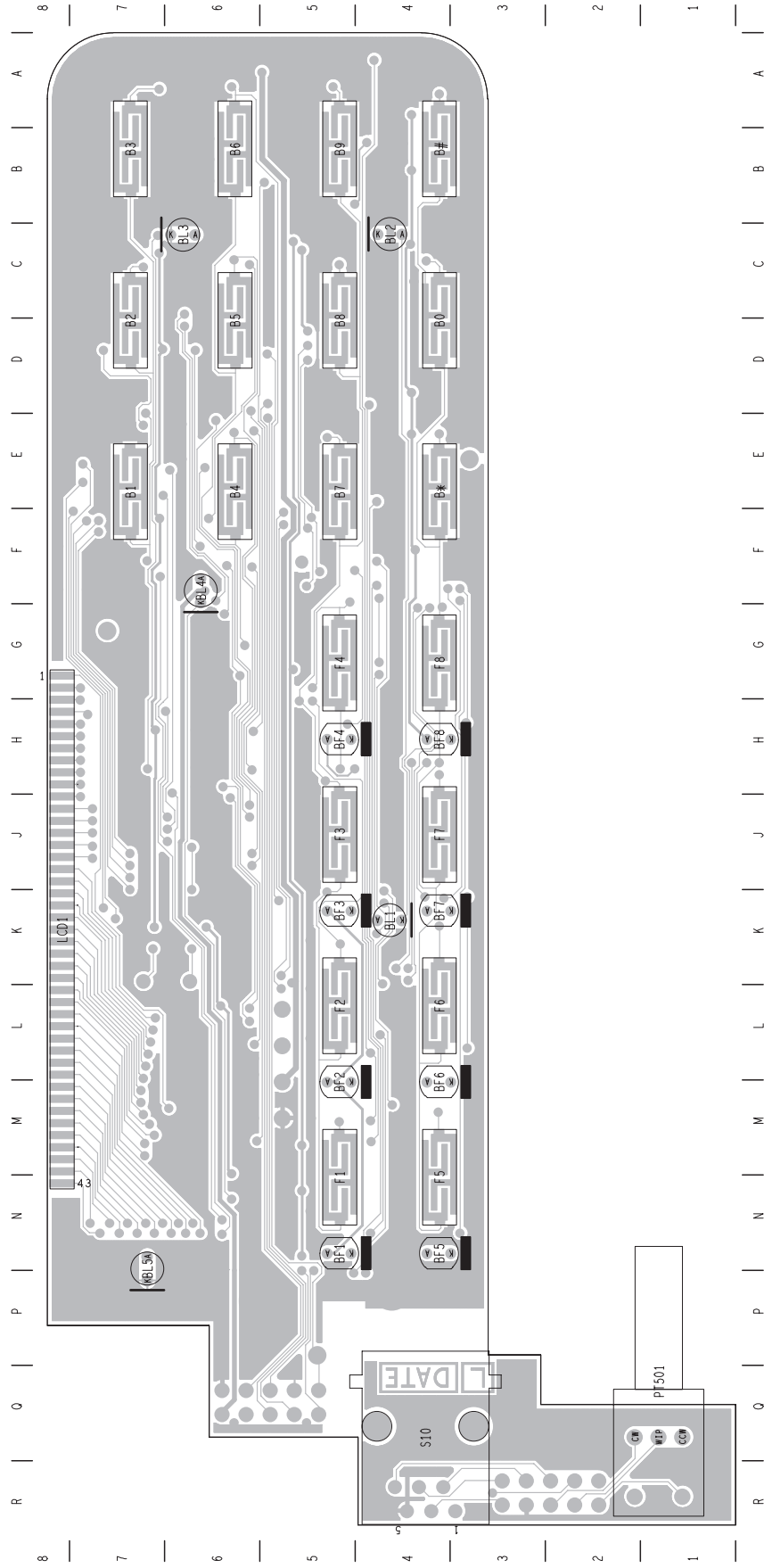

6.5 X2H221- PCB Circuit Diagram (page 1 of 1)

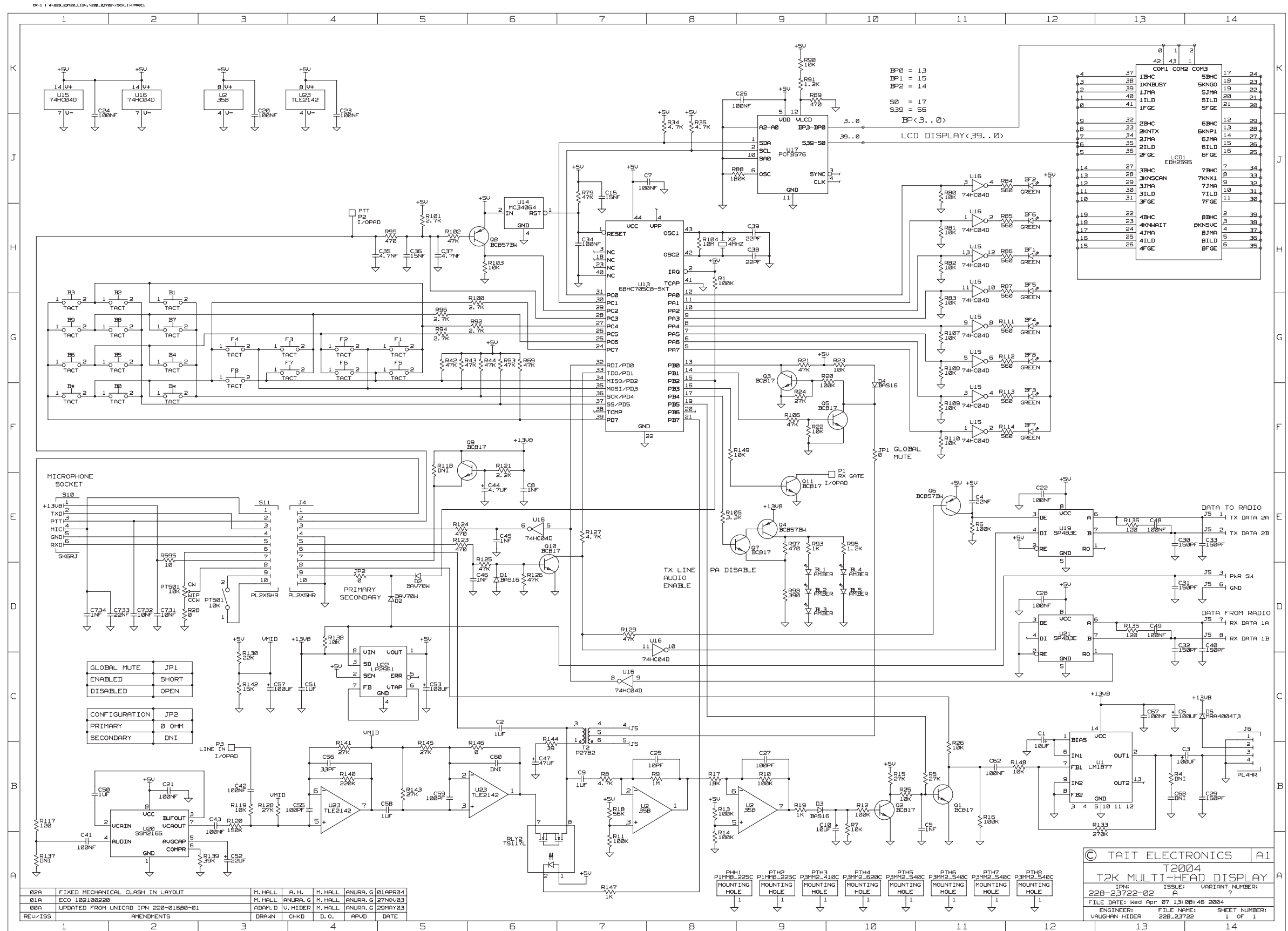

REV/ISS	AMENDMENTS	DRAWN	CHKD	APVD	DATE
02A	FIXED MECHANICAL CLASH IN LAYOUT	M. HALL	A. H.	M. HALL	ANURA_G 01APR04
01A	ECD 102102200	M. HALL	ANURA_G	M. HALL	ANURA_G 27NOV03
00A	UPDATED FROM UNICAD IPN 220-01680-01	ADAM.D	U. HIDER	M. HALL	ANURA_G 29MAY03

© TAIT ELECTRONICS		A1
T2004		
T2K MULTI-HEAD DISPLAY		
TRD	ISSUE:	VARIANT NUMBER:
228-23722-02	A	
FILE DATE: Wed Apr 07 13:08:46 2004	ENGINEER:	FILE NAME:
	VAUGHAN HIDER	228-23722
		SHEET NUMBER:
		1 OF 1

7 Testing the X2H2xx control heads

Test equipment

- T2020 or T2040 radio with power supply in known working order.
- X2AM01 radio interface board in known working order.
- Microphone, speaker and power supply for control head.
- 8 way micromatch loom to connect X2AM01 to radio.
- 8 way micromatch loom to connect primary head under test.
- Radio communications test set.
- Multimeter.
- 20MHz oscilloscope, preferably digital storage.
- Standard tools, screwdrivers, etc.

Setting up

1. If T2004 control head under test is not configured as a primary head, temporarily fit shorting link to position JP2.
2. Connect SK1 of the X2AM01 board to connector S9 of radio logic board.
3. Connect SK3 of the X2AM01 board to connector J5 of the control head under test.
4. Connect power and microphone to the primary control head as usual.
5. Connect the radio's antenna jack to the RF input/output of the communication test set.
6. Connect a suitable 13.8VDC 10A power supply to the radio.

Testing

Power

- Check there is always +13.8V on U22 pin 8 and U1 pin 14.
- Check U22 pin 3 is high when the control head switch (volume control) is off, and around 0V when the control head is switched on.
- Check there is 5V on U22 pin 1 when control head is on.
- Check 1/2 VCC rail on C57 is around 2-3V.

Microprocessor

- Check reset line U14 pin 1 is at 5V.
- Use oscilloscope to check for 4MHz oscillation on crystal X2 or resistor R104.
- With micromatch cable on J5 removed, switch on control head with any key held down. On power up the display should always show software version number (2372A510). When key is released, all display segments and LEDs should flash.

Audio

- Transmit on microphone and apply audio (E.G. whistle into microphone), check for approx. -15dBm line audio on RLY2 pins 7 and 8. Radio should enter transmit mode and have normal TX deviation. "TX" should appear on the LCD.
- With the radio in receive mode, generate a test signal of -70dBm RF level, 60% system deviation (1.5kHz for narrow band, 3kHz for wide band). Check for approx. -10dBm line audio at C2. Check Q1 base is at 0V, so PA is not muted. Check that audio level into PA on U1 pin 7 varies with volume control. Check for high level audio output on U1 pin 2.

Global mute

- Ensure link JP1 is fitted to enable global mute.
- When not transmitting and microphone off hook (hang up stud not earthed), check that JP1 is at 5V.
- With microphone on hook (hang up stud connected to 0V), check that JP1 is at 0V.
- Temporarily fit a 1k ohm resistor between JP1 and U22 pin 1. Make radio receive a test signal and adjust volume so audio can be heard in control head speaker while microphone is off hook. Speaker should mute when microphone is placed on hook. Remove link resistor when finished.

Data

- Turn radio off then on using control head volume switch. Use oscilloscope to check for 5V TTL data on U21 pin 1. Note that data only lasts a few seconds after power on.
- After power up, confirm that key presses on control head appear as 5V TTL data on U19 pin 4. Connect oscilloscope channel 1 on J5 pin 1, channel 2 on J5 pin 2. Verify differential mode data exists on RS485 line when keys are pressed.

PC programming

- Connect T2000 programming cable to microphone socket, check for approx. 13.8V on microphone socket S10 pin 1.
- Verify that radio can be read correctly with appropriate radio programming software.

Part C X2AM01 Radio Interface

This part provides general and technical information about the X2AM01 Multi-Head Radio Interface.

The following topics are covered in this part:

- Section 1 Introduction
- Section 2 Circuit Description
- Section 3 I/O Connections
- Section 4 Fitting PCB into Radio
- Section 5 X2AM01 Multi-Head Radio Interface PCB
- Section 6 Testing the X2AM01 radio interface

1 Introduction

1.1 The X2AM01 Multi-Head Radio Interface PCB

The X2AM01 Multi-Head Radio Interface PCB is the interface between a standard T2020 or T2040 radio and the remote control heads in the T2004 Multi-Control Head system.

The PCB fits inside a dummy (Clayton's) control head, which replaces the standard control head of the radio. Only one X2AM01 Multi-Head Radio Interface PCB is used in the system.

2 Circuit Description

This section provides circuit information for the X2AM01 Multi-Head Radio Interface PCB.

Audio

The PCB provides a balanced 600 Ohm line interface for both the Tx and Rx audio.

Power

The PCB is supplied with 13.8V from the radio. A single 5V supply is provided for circuitry on the X2AM01 Interface PCB only.

The remote power switch line SK3-3 (controlled by the Primary head) enables the 5V regulator, which in turn draws current from the radio (SK1-1) and causes the radio to power up.

Data

A separate RS485 transmitter and receiver provide the data communications between the radio and control heads.

Connections

The connection to the radio is the same as for a standard T2000 control head (micromatch cable to SK1). Connection to the remote control heads is via the micromatch loom at SK3, which connects to the RJ45 Wallbox. The wallbox connects to the multi-drop cable, which connects to the RJ45 Wallbox for each control head.

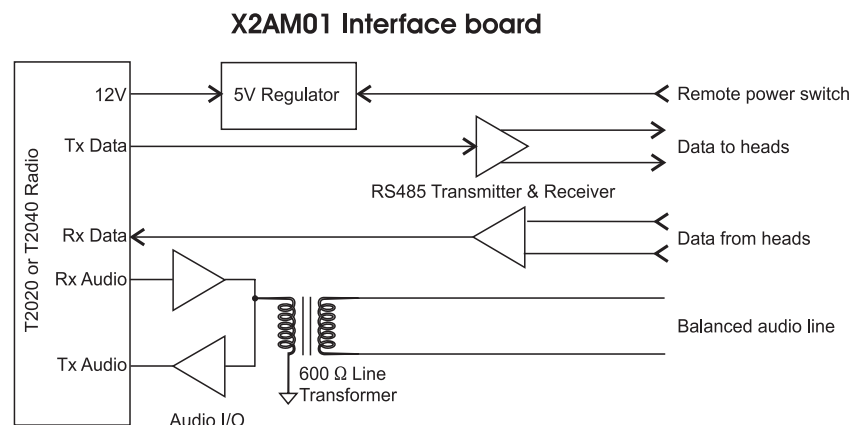

3 I/O Connections

This section describes the I/O connections on the board.

3.1 SK1: 8 Way Micromatch Socket to Radio

Pin	Signal	Description
1	+13.0V_UNSW	Unswitched 13.8V from radio
2	GND	Common ground
3	RX_DATA	Data from heads to radio, 5V logic levels
4	TX_DATA	Data from radio to heads, 5V logic levels
5	GND	Common ground
6	AF	Receiver audio, approx. -4dBm
7	MIC_IN	Transmitter audio, approx. -30dBm
8	N/C	Not connected

3.2 SK3: 8 Way Micromatch Socket to Control Heads

Pin	Signal	Description
1	DATA 2A	Data from heads A
2	DATA 2B	Data from heads B
3	PWR SW	Remote power switch, Low=power on
4	Audio	Balanced audio line
5	Audio	Balanced audio line
6	GND	Common ground
7	DATA 1A	Data to heads A
8	DATA 1B	Data to heads B

4 Fitting PCB into Radio

The T2004 Multi-Control Head Installation Manual M2004-00-100-315 should be referred to for the installation process.

5 X2AM01 Multi-Head Radio Interface PCB

This section contains all PCB information for the Multi-Head interface PCB.

The following information is included for the board:

- PCB parts list
- Grid references
- PCB layout drawings for both sides of the board
- Circuit diagram.

5.1 X2AM01 Rev 008 Parts List

IPN 228-23721-01

Ref	IPN	Description
C1	015-27100-10	Cap Cer 0805 1m+80-20% Y5v 16v
C2	015-26100-08	Cap Cer 0805 100n 10% X7r 50v
C3	015-26100-08	Cap Cer 0805 100n 10% X7r 50v
C6	015-23100-01	Cap Cer 0805 100p 5% NPO 50v
C7	015-24100-08	Cap Cer 0805 1n 10% X7r 50v
C8	015-24100-08	Cap Cer 0805 1n 10% X7r 50v
C9	016-09100-01	Cap Elec SMD 100u 6.6*6.6 6.3v
C10	015-26100-08	Cap Cer 0805 100n 10% X7r 50v
C11	015-24100-08	Cap Cer 0805 1n 10% X7r 50v
C14	015-24100-08	Cap Cer 0805 1n 10% X7r 50v
C15	015-26100-08	Cap Cer 0805 100n 10% X7r 50v
C18	015-26100-08	Cap Cer 0805 100n 10% X7r 50v
C21	016-08100-01	Cap Elec SMD 10m 4*5.2 16v 20%
C26	015-22330-01	Cap Cer 0805 33p 5% NPO 50v
C36	015-22330-01	Cap Cer 0805 33p 5% NPO 50v
C39	015-23100-01	Cap Cer 0805 100p 5% NPO 50v
D1	001-10284-51	Diode SMD BZX284B5V1 Zensod110
R1	036-14180-00	Res M/F SMD 0805 1k8 5%
R2	036-15560-00	Res M/F SMD 0805 56k 5%
R3	036-14100-00	Res M/F SMD 0805 1k 5%
R4	036-14150-00	Res M/F SMD 0805 1k5 5%
R5	036-14150-00	Res M/F SMD 0805 1k5 5%
R7	036-15270-00	Res M/F SMD 0805 27k 5%
R8	036-12390-00	Res M/F SMD 0805 39e 5%
R9	036-15270-00	Res M/F SMD 0805 27k 5%
R10	036-15220-10	Res M/F SMD 0805 22k 1%
R12	036-15120-10	Res M/F SMD 0805 12k 1%
R13	036-15270-00	Res M/F SMD 0805 27k 5%
R17	036-15560-00	Res M/F SMD 0805 56k 5%
R18	036-15220-10	Res M/F SMD 0805 22k 1%
R25	036-14150-00	Res M/F SMD 0805 1k5 5%
R26	036-14150-00	Res M/F SMD 0805 1k5 5%
R27	036-13150-00	Res M/F SMD 0805 150e 5%
R28	036-13150-00	Res M/F SMD 0805 150e 5%
R38	036-14820-10	Res M/F SMD 0805 8k2 1%
R42	036-15270-00	Res M/F SMD 0805 27k 5%
SK1	240-10000-05	Conn SMD 8w 2r Skt M/Match
SK3	240-10000-05	Conn SMD 8w 2r Skt M/Match
T1	054-00010-20	Xmfr SMD Ct Etal2782
U1	002-10021-42	IC SMD TLE2142CD Opamp S08
U2	002-12951-00	IC SMD LP2951CM Adj Vltge Reg
U4	002-10004-83	IC SP483EEN RS485 Xcvr/Esd S08
U5	002-10004-83	IC SP483EEN RS485 Xcvr/Esd S08
	219-02013-00	T2K 8way Loom Logic-Ctrl Hd
	228-23721-01	Pcb T2020/40 M/Ctrl Hd Rad I/F
	365-00011-54	Lbl White R1556/2 90*24mm
	399-00010-51	Bag Plstc 75*100mm
	399-00010-86	Bag Static Shlding 127x203mm
	349-00020-32	Scrw M3*8mm T/T P/P Bz
	353-00010-16	Wshr M3 Fibre 8mm Od*1.5mm

5.2 X2AM01 Rev 008 Grid Reference

Ref	PCB	Circuit Diagram
C1	A2	1C3
C2	B3	1E6
C3	B2	1B9
C6	C1	1C6
C7	D4	1D8
C8	E2	1D8
C9	A1	1C2
C10	C4	1E3
C11	G2	1D9
C14	G3	1D10
C15	B1	1B7
C18	C1	1B6
C21	A4	1E5
C26	C1	1C6
C36	B1	1C4
C39	B1	1C5
D1	F1	1F8
MT1	D3	1D8
MT2	D2	1D8
MT3	G2	1D9
MT4	G3	1D10
R1	C4	1C3
R2	C1	1C6
R3	C4	1B2
R4	B2	1G7
R5	C2	1F7
R7	C1	1C6
R8	C1	1D6
R9	C1	1C6
R10	A2	1D2
R12	A2	1C3
R13	C1	1C5
R17	A1	1C4
R18	C4	1B3
R25	B3	1E7
R26	C3	1E7
R27	C3	1E7
R28	C2	1F7
R38	C4	1B3
R42	C2	1C5
SK1	F4	1B2 1G2 1C2 1D2 1E2
SK3	F2	1C9 1G9 1F9 1E9
T1	D1	1C7
TP1	C1	1D4
TP2	C1	1C7
U1	B1	1B9 1C4 1C6
U2	B4	1E5
U4	B2	1F7
U5	B3	1E7

5.3 228-23721-01 PCB Top Side

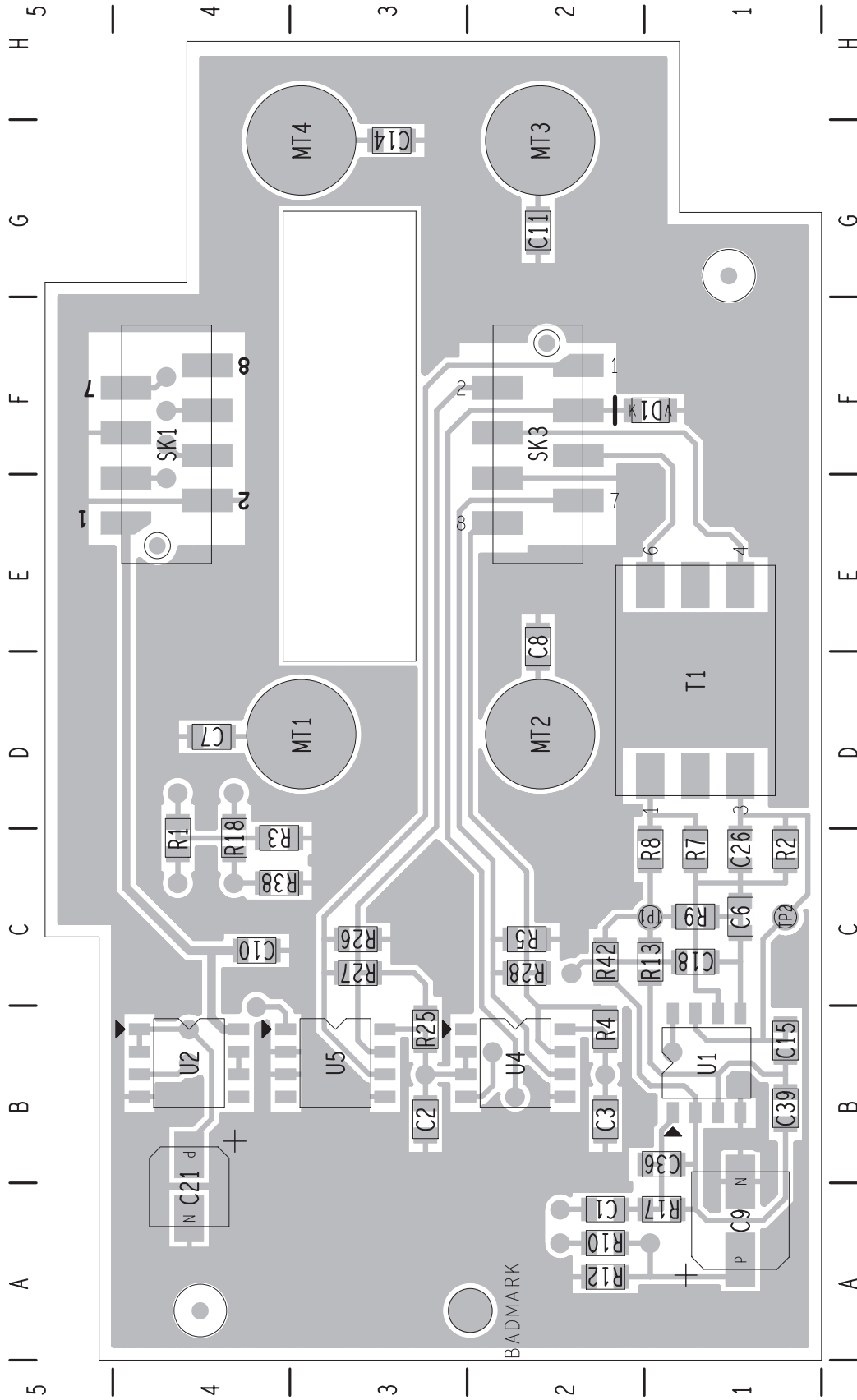

5.4 228-23721-01 PCB Bottom Side

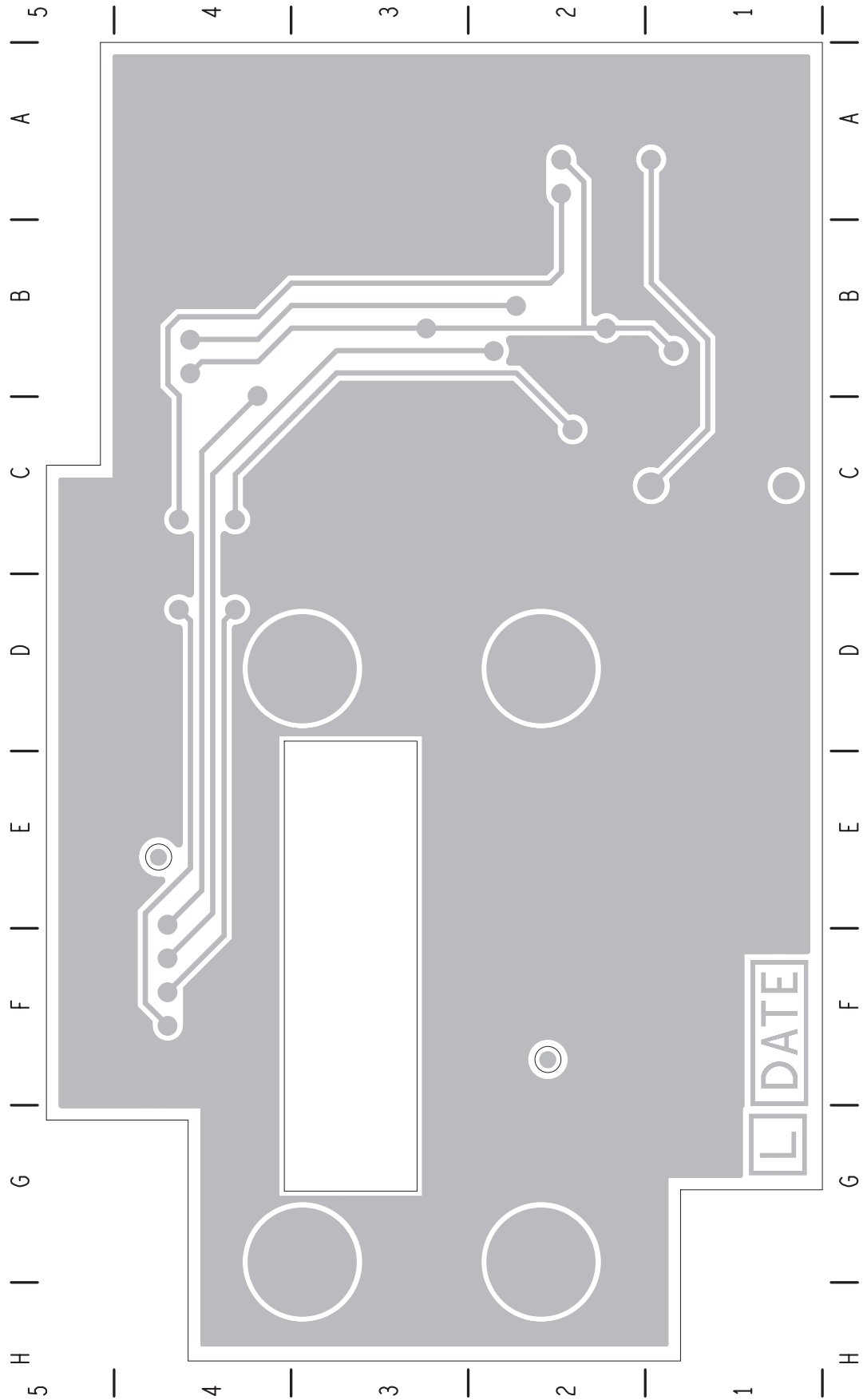

6 Testing the X2AM01 radio interface

Test equipment

- T2020 or T2040 radio with power supply in known working order.
- X2H2x1 Primary control head in known working order.
- Microphone, speaker and power supply for control head.
- 8 way micromatch loom to connect X2AM01 to radio.
- 8 way micromatch loom to connect primary head.
- Radio communications test set.
- Multimeter.
- 20MHz oscilloscope, preferably digital storage.
- Standard tools, screwdrivers, etc.

Setting up

7. Connect SK1 of the X2AM01 board to connector S9 of radio logic board.
8. Connect SK3 of the X2AM01 board to connector J5 of the primary control head.
9. Connect power and microphone to the primary control head as usual.
10. Connect the radio's antenna jack to the RF input/output of the communication test set.
11. Connect a suitable 13.8VDC 10A power supply to the radio.

Testing

Power

- Check there is always +13.8V on U2 pin 8.
- Check U2 pin 3 is high when the control head switch (volume control) is off, and around 0V when the control head is switched on.
- Check there is 5V on U2 pin 1 when control head is on.
- Check 1/2 VCC rail at TP1 is around 2-3V.
- Check radio turns off (0V on radio logic board S14 pin 1) when control head is off, check radio is on (+13.8V on S14 pin 1) when control head is on.

Audio

- Transmit on microphone and apply audio (E.G. whistle into microphone), check for approx. -15dBm line audio at TP2, check for approx. -30dBm mic audio on SK1 pin 7. Radio should enter transmit mode and have normal TX deviation.
- With the radio in receive mode, generate a test signal of -70dBm RF level, 60% system deviation (1.5kHz for narrow band, 3kHz for wide band). Check for approx. -4dBm of receiver audio on SK1 pin 6. Check for approx. -10dBm line audio on TP2. Ensure audio appears on 600 ohm balanced line (measure between SK3 pins 4 and 5).

Data

- Turn radio off then on using control head volume switch. Use oscilloscope to check for 5V TTL data on SK1 pin 4. Note that data only lasts a few seconds after power on. Connect oscilloscope channel 1 on SK3 pin 7, channel 2 on SK3 pin 8. Verify differential mode data exists on RS485 line at radio power on.
- After power up, confirm that key presses on control head appear as 5V TTL data on SK1 pin 3.